

3 规格 SPECIFICATIONS

1	相数 Number of Phase	4
2	步距角 Step Angle	1.8° ±5%
3	转子惯量 Rotor Inertia	930g · cm ²
4	绝缘电阻 Insulation Resistance	100MΩ 500VDC
5	绝缘等级 Insulation Class	B (130℃)
6	环境温度 Ambient Temperature	-20℃ to 50℃
7	环境湿度 Ambient Humidity	15% to 95%
8	电机重量 Motor Weight	Approx 1.4 kg

3 WIRINGS CONNECTION DIAGRAM

原型号: 60BYGH301B

	最大静转矩 Holding Torque (2 phases on) N. cm ±10%	额定电流/相 Rated Current/Phase (Amps DC)	相电阻 Resistance/Phase (ohms) ±10%	电压/相 Voltage/Phase (V DC)	电感/相 Inductance/Phase (mH) ±20% Typical (1kHz)
单极性驱动 Unipolar	220	3.0	1.4	4.2	3.5
串接 Bipoar (Series)	311	2.12	2.8	5.94	13.65
并接 Bipoar (Parallel)	311	4.24	0.7	2.97	3.5

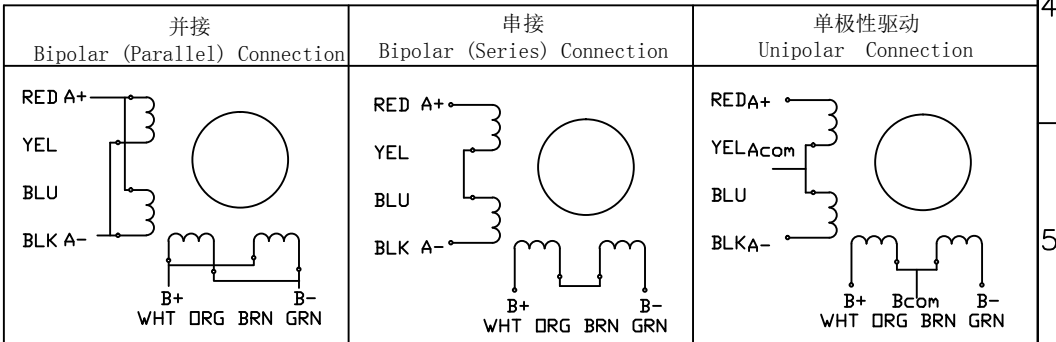

			Unit:mm 第一角画法 First angle method 未注线性与角度尺寸公差 Tolerances for linear and angular dimensions without individual tolerance indications GB/T 1804-m eqv ISO 2768-1:m 未注形状与位置尺寸公差 Geometrical tolerances for features without individual tolerance indications GB/T 1184-k eqv ISO 2768-2:k
V2.0	HTPS1610133 新版本	20161014	
V1.0	xxxx	20120308	
REV.	版本记录 REVISION RECORD	DATE	UNLESS OTHERWISE SPECIFIDE

设计 DESIGN	CX1	20161013
校核 CHECK		
工艺 TECHNOLOGY		
标准化 STANDARD		
批准 APPROVE		
NAMES	SINGATURE	DATE

CW-motor

常州创伟电机电器有限公司
 Changzhou Chuangwei Motor & Electric Apparatus Co.,Ltd
 TYPE: HYBRID STEPPING MOTOR | SCALE XX | Rev. 1.0 | SHEET 1 OF 1
 Model: 60BHH86-300E-24DB